

TECHNICAL FEATURES

Model	Dimensions	Hardox thickness	Tare	Capacity
SGB2	7,50 m x 2,54 m	5 mm	6500 kg	18 m ³

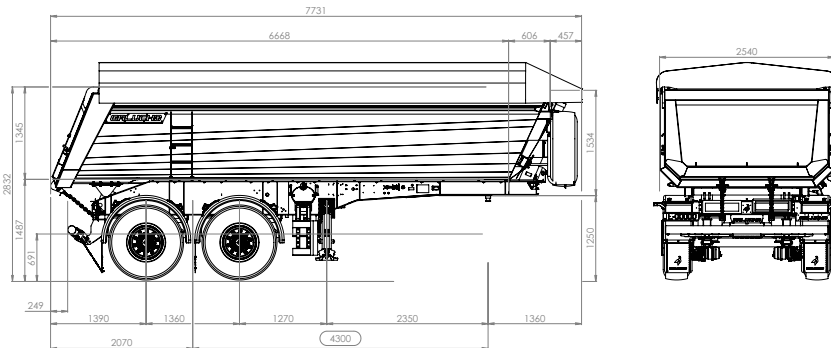

GALUCHO

NOVELTY

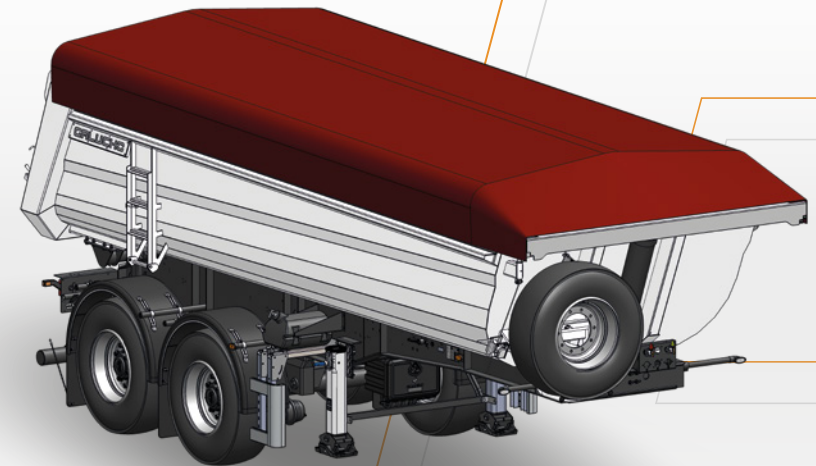

OPTIONAL EQUIPMENT

- Bipartite or tripartite bodywork
- Loading manometer
- Box in HARDOX 450 - Thick. 5, 6, 8 ou 10 mm
- Fire extinguisher box
- Capacity: 18 – 25 m³
- Metal toolbox
- Hydraulically opening, single-acting rear headboard
- Electric sliding awning
- Hydraulically-opening, double-acting rear headboard
- Back-up beeper
- Asphalt Kit (Folding Bumpers, Rear Tray, Rear White Light, Light Protection, Bellows Protection)
- Michelin tyres

MAIN ADVANTAGES

- Reduced tare, with reduced consumption
- Pneumatic suspension
- Disc brake, EBS system

SGB2 / NEW 2-AXLE TIPPER SEMITRAILER.

GALUCHO

GALUCHO - Indústrias Metalomecânicas, S.A.
Avenida Central, N°4 | 2705-737 São João das Lampas | Sintra - Portugal

geral@galucho.pt

(+351) 219 608 500

www.galucho.pt



Engravings and technical data are for guidance only, subject to change without notice.

STANDARD FEATURES

